

## 50 mm LASER TRACKBALL

### X50

Utilizing the latest and most advanced laser tracking technology, the X50 Series Laser Trackerball™ is an extremely high specification, contact-less device, ideal for the most demanding of cursor control applications.

The laser tracking engine provides accurate cursor motion at all speeds and on virtually any ball, combining the benefits of solid state sensing (no moving parts except the ball). The X50 trackballs are available with a variety of electrical outputs and sealing to IP68. The solid state design allows the device to be subjected to extreme conditions and provides the user with the ability to wash down, decontaminate, and sterilise, making it the ideal trackball for a wide range of demanding applications and environments.

The unit has been designed to be back of panel mounted as part of OEM keyboards and consoles.



- Solid state sensing technology  
Laser tracking engine
- Sealing to IP68
- Output: PS/2 & USB or Quadrature
- Smooth operation in rugged environments
- Various top plate configurations
- Custom connector options
- VX3™ integrated zoom feature for scroll wheel functionality

### SPECIFICATIONS

#### Mechanical

Weight	150 grams
Ball	Epoxy Resin, 50,8 mm
Tracking Force	20 grams nominal - damper ring 30 - 80 grams - PTFE seal
Ball Load	200N Maximum downward pressure (20 Kg) for 2 mins.
Resolvable Ball Speed	40 Inches/sec.
Housing Material	Polycarbonate / ABS
Transducer	Optical Navigation Technology (solid state sensing)
Mounting Position	All angles
Sealing gasket	Cellular silicone

#### Electrical

Supply voltage	4.4V to 5.25V D.C.
Supply current	25mA typical, 30mA maximum
Resolution	1200 counts per ball revolution @ 1 IPS (inches per second) +/- 10% (Quadrature protocol) 2400 counts per ball revolution @ 5 IPS (inches per second) +/- 10% (USB, PS/2 protocol)
Output connector	10 Way JST, right-angled header, part no. S10B-PH-SM3-TB
Switch Inputs (USB, PS/2)	3 switches: left, middle, and right. Connection through 4-way JST, right-angled header, part no: S4B-PH-SM3-TB
Laser safety class	Embedded class 1M laser safety, IEC 60825-1

#### Environmental

Operating temperature	0°C to +55°C (IEC 60068-2-1, IEC60068-2-2)
Storage temperature	-40°C to +85°C (IEC 60068-2-1, IEC60068-2-2)
Operating humidity	93% RH @ 40°C, non-condensing (IEC 60068-2-78)
Storage humidity	10%-95% non-condensing (IEC 60068-2-78)
Vibration	5g, 10-500Hz, 1 octave/min, 10 sweep cycles (IEC 60068-2-6)
Operating Shock	15g/11ms, ½ sine, 3 shocks in +ve and -ve direction, all 3 axes (IEC 60068-2-27)
Non-operating shock	50g/11ms, ½ sine, 3 shocks in +ve and -ve direction, all 3 axes (IEC 60068-2-27)
Mechanical lifetime	1 million ball revolutions
MTBF	in excess of 80,000 hours (MIL-STD-217F)
ESD	15kV air-discharge and 8kV contact discharge (IEC 61000-4-2)
EMC	Radiated immunity - limits according to level 3 of IEC 61000-4-3 Radiated emissions to EN55022 class B
Sealing capability	IP68 (BS EN 60529)

### 50 mm LASER TRACKBALL

#### DIMENSIONAL DRAWING

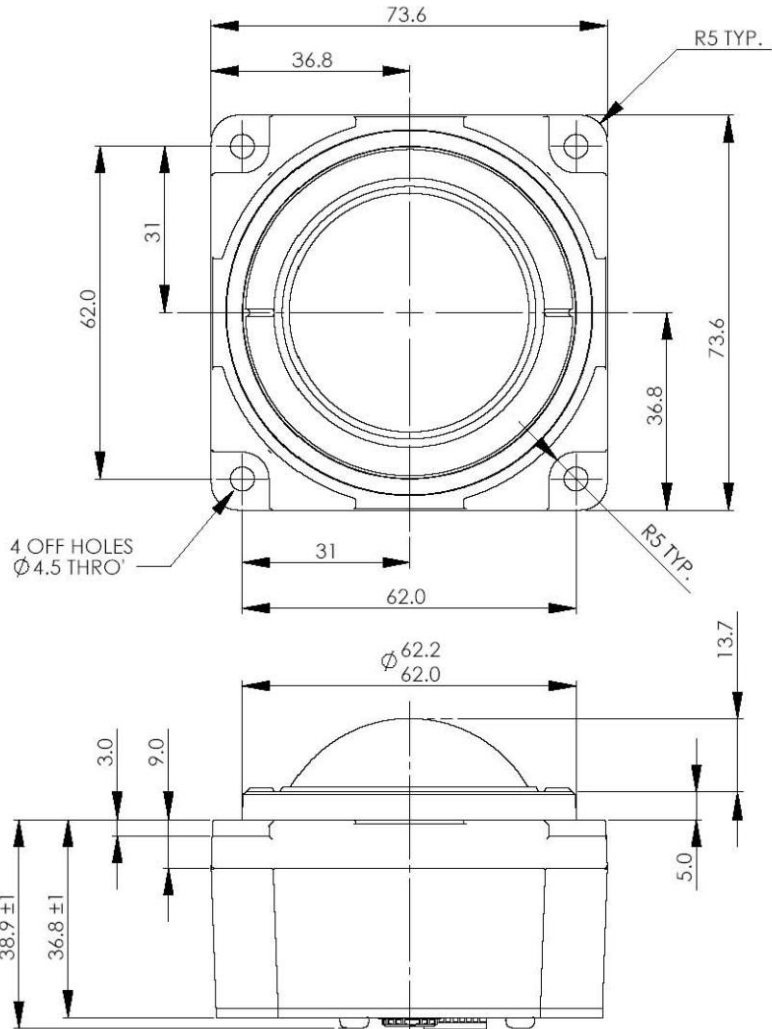
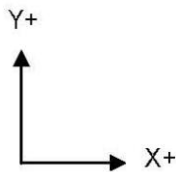
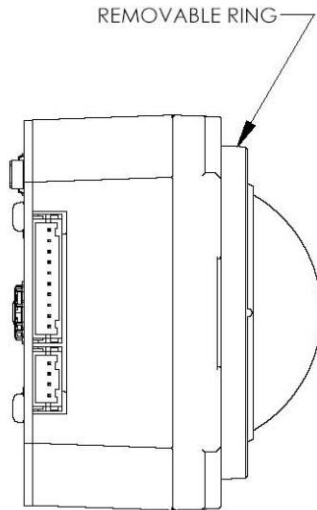

#### Quadrature output

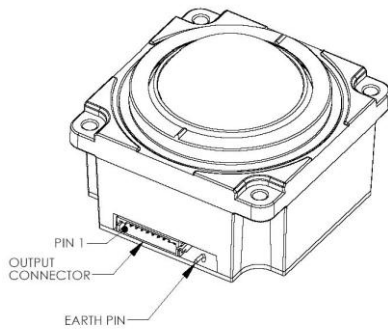

#### PS/2 & USB output

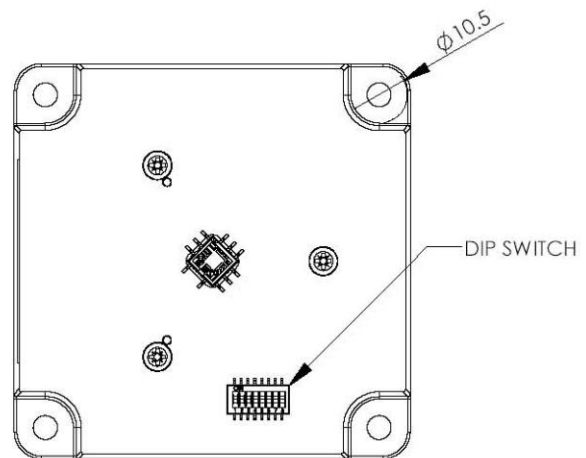
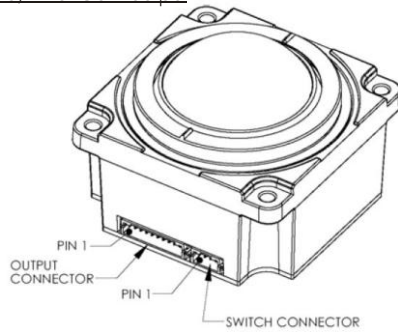

The company reserves the right to alter without prior knowledge the specification or design of any standard product or service.

## 50 mm LASER TRACKBALL

### CONNECTION DETAILS QUADRATURE OUTPUT

Output Connector : P1

Description: 10 Way JST, right-angled header.  
 Manufacturer: JST (or equivalent)  
 Part No: S10B-PH-SM3-TB  
 Mating connector: PH, CR or KR types (e.g. PHR-8)

Pin Number	Quadrature
1	X1
2	X2
3	Y1
4	Y2
5 and 6	EARTH
7	5V D.C
8 and 9	See Note 1
10	0V

Note 1 : Pin to be left floating (unconnected)

### CONNECTION DETAILS PS/2 - USB OUTPUT

Output Connector : P1

Description: 10 Way JST, right-angled header.  
 Manufacturer: JST (or equivalent)  
 Part No: S10B-PH-SM3-TB  
 Mating connector: PH, CR or KR types (e.g. PHR-10)

Pin Number	PS/2 & USB
1, 2, 3 and 4	See note 1
5 and 6	EARTH
7	5V D.C
8	PS/2 Data, D-
9	PS/2 Clock, D+
10	0V

Note 1 : Pin to be left floating (unconnected)

Switch Input Connector : P2

Description: 4-way JST, right-angled header.  
 Manufacturer: JST (or equivalent)  
 Part No: S4B-PH-SM3-TB  
 Mating connector: PH, CR or KR types (e.g. PHR-4)

Pin Number	Function
1	Left switch
2	Middle switch
3	Right switch
4	0V

### Switch Schematic

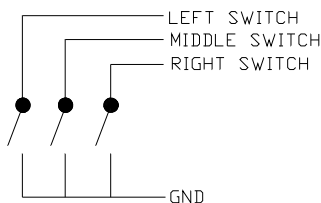

### OPTIONAL LEAD ASSEMBLIES

Standard Lead assemblies for connection to the X50 unit are available. Other lead assemblies can also be supplied to customer specifications.

Part Number	Leads / Adapters	Description
OC6010160	Output cable PS/2	1,6 m shielded cable with 6 pin mini DIN plug
OC5010160	Output cable USB	1,6 m shielded cable with USB type A plug
IC040035	Switch Input	4 way JST style - bare wires, 35 cm long
IC101035	Interconnection	Interconnection cable, 35 cm long

## 50 mm LASER TRACKBALL

### CONFIGURATION

The X50 trackball provides features that may be selected using the DIP switch located on the printed circuit board. This table details the assigned function of each switch.

#### DIP Switch Functions quadrature Trackballs

DIP Switch	Function	OFF	ON
1	Orientation 1 Setting	See Figure.1	See Figure.1
2	Orientation 2 Setting	See Figure.1	See Figure.1
3	Not used	N/A	N/A
4	Not used	N/A	N/A
5	Not used	N/A	N/A
6	Factory setting	N/A	N/A
7	Not used	N/A	N/A
8	Not used	N/A	N/A

Factory default setting: All DIP switches OFF

#### DIP Switch Functions PS/2 - USB Trackballs

DIP Switch	Function	OFF	ON
1	Orientation 1 Setting	See Figure.1	See Figure.1
2	Orientation 2 Setting	See Figure.1	See Figure.1
3	VX3 - Virtual 3 Axis Function	Feature disabled	Feature enabled
4	Smart Feature	Feature disabled	Feature enabled
5	Tracking mode	Ballistic tracking	Linear tracking
6	Factory setting	N/A	N/A
7	Factory setting	N/A	N/A
8	N/A	N/A	N/A

Factory default setting: All DIP switches OFF

#### Orientation

The orientation function allows the user to mount the X50 trackball device in one of four positions (see figure. 1 below). The orientation of the device is determined by the direction in which the output connector is facing (when viewed from the top of Trackerball device). The trackball orientation can be selected to accommodate customer requirements for connector location and wiring.

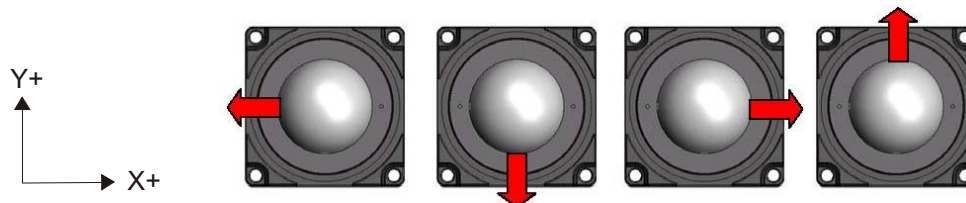

Switch 1	Orientation 1	Off	On	Off	On
Switch 2	Orientation 2	Off	Off	On	On

Figure.1 Mounting Orientations

## 50 mm LASER TRACKBALL

### CONFIGURATION

#### VX3™

VX3 is patent protected facility that provides the same 2 modes of functionality as a scroll wheel on a 3-axis mouse.

#### Operation:

Press middle button once to latch scroll mode one (e.g. dynamic pan feature);

Press middle button again to latch scroll mode two (e.g. 3<sup>rd</sup> axis zoom feature);

Further middle button presses toggles between scroll mode one and scroll mode two;

Press either left or right buttons to cancel feature and resume normal X-Y cursor operation

#### Smart Switch

A patent protected button latch facility.

#### Operation:

Press right button for 3 seconds or more to enable;

Once enabled, pressing any button for approximately 1 second latches that button on;

Press any button momentarily to de-latch;

Disabled with a further press of the right button for 3 seconds or more;

#### Tracking Mode

**Ballistic Tracking:** Intuitive tracking algorithm to provide increased cursor resolution when tracking fast whilst retaining the original resolution for tracking accurately at slow speeds.

**Linear Tracking:** No tracking algorithm. 1200 counts per ball revolution maintained at all tracking speeds.

### ORDER INFO

OUTPUT	DAMPER RING	PTFE SEAL
Quadrature	<b>X50-70021D</b>	<b>X50-70023D</b>
PS/2 & USB	<b>X50-76021D</b>	<b>X50-76023D</b>

#### MANUFACTURER

Cursor Controls Ltd, Brunel Drive,  
Newark, U.K

Tel: ++44 (0) 1636 615600

Fax: ++44 (0) 1636 615601

Website : [www.cursorcontrols.com](http://www.cursorcontrols.com)

E-mail: [sales@cursorcontrols.com](mailto:sales@cursorcontrols.com)



#### EUROPEAN SALES & SERVICE CENTER

NSI bvba, Haakstraat 1A,

B-3740 Bilzen, Belgium

Tel. : +32 89 51 90 00

Fax : +32 89 91 90 09

Website : [www.nsi-be.com](http://www.nsi-be.com)

E-mail : [info@nsi-be.com](mailto:info@nsi-be.com)

